



**Let's grow together**

# ES15-15ES

# ES15-33DM

## Electric Stacker 1.5t

- 1.5 Ton electric walkie stacker with smallest turning radius;
- High quality mast system meets international regulation;
- Professional cylinder & chain layout provides clear view;
- Maintenance free battery and on board charger

**EP EQUIPMENT CO.,LTD**  
[www.ep-equipment.com](http://www.ep-equipment.com)



## FEATURE

### Performance:

- The innovative AC system offers strong power, accurate control and excellent performance.
- High strength vertical gearbox provides reliable uptime.
- Low-noise and durable hydraulic unit, high quality cylinder as well as hose ensure the high reliability of hydraulic system.
- AMP connector and durable electric wires greatly reduce malfunctions of components.
- H shape channel mast improves the strength of the whole truck.

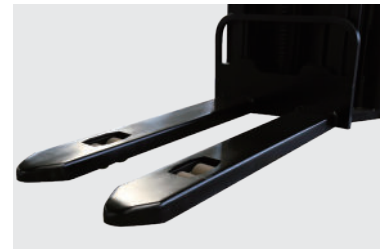

### Safety:

- Safe hydraulic system design prevents mast from falling down abruptly when hydraulic pipeline cuts off.
- Emergency reverse belly button protects the operator from getting hurt.
- Emergency disconnecter will cut off power source to avoid accident when truck goes out of control.
- Multiple lifting limit protection ensures safety.
- Automatic switch to lower speed when the fork reaches its setting height.
- Anti-rolling back brake keeps the truck from skidding down when truck is out of control or travelling on ramp.
- Long aside tiller reduces operator's hazards.

### Operation:

- Ergonomic tiller bounded with key switch, BDI and trouble shooting indicator enhances easy and accurate operation.
- Long tiller offers easier operation.
- Compact chassis design offers smallest turning radius needed.
- Side operating ensures excellent visibility.
- On-board Charger.

### Maintenance:

- Maintenance-free Battery.
- Battery display indicator with hour meter, reminds operator of charging on time (optional).
- Easy Maintenance — detachable rear panel.
- Vertical motor makes the inspection & service much more convenient.
- Easy Access of Hand Set.
- Low-voltage Cut-off Protection.

# Electric Stacker 1.5t

## ES15-15ES

Distinguishing mark				
1.1	Manufacturer			EP
1.2	Model designation			ES15-15ES
1.3	Drive unit			Electric
1.4	Operator type			Pedestrian
1.5	rated capacity	Q	kg	1500
1.6	Load center distance	c	mm	600
1.8	Load distance, centre of drive axle to fork	x	mm	805
1.9	Wheelbase	y	mm	1240
Weight				
2.1	Service weight (include battery)		kg	755
2.2	Axle loading, laden driving side/loading side		kg	805/1450
2.3	Axle loading, unladen driving side/loading side		kg	545/210
Types, Chassis				
3.1	Tyre type Driving wheels/Loading wheels			PU/PU
3.2	Tyre size, driving wheels (diameter×width)		mm	Φ230×75
3.3	Tyre size, loading wheels (diameter×width)		mm	Φ80×60
3.4	Tyre size, caster wheels (diameter×width)		mm	Φ130×55
3.5	Wheels, number driving, caster/loading (x=drive wheels)		mm	1x +2/4
3.6	Track width, front, driving side	b <sub>10</sub>	mm	538
3.7	Track width, rear, loading side	b <sub>11</sub>	mm	400
Dimensions				
4.2	Height, mast lowered	h <sub>1</sub>	mm	2128
4.3	Free lift	h <sub>2</sub>	mm	
4.4	Lift height	h <sub>3</sub>	mm	3227
4.5	Height, mast extended	h <sub>4</sub>	mm	3743
4.9	Height drawbar in driving position min./max.	h <sub>14</sub>	mm	1150/1480
4.15	Lowered height	h <sub>13</sub>	mm	88
4.19	Overall length	l <sub>1</sub>	mm	1740
4.20	Length to face of forks	l <sub>2</sub>	mm	575
4.21	Overall width	b <sub>1</sub>	mm	800
4.22	Fork dimensions	s/ e/ l	mm	60×170×1150
4.24	Fork carriage width	b <sub>3</sub>	mm	680
4.25	Outside width of the forks	b <sub>5</sub>	mm	570
4.32	Ground clearance, center of wheelbase	m <sub>2</sub>	mm	28
4.34.1	Aisle width for pallets 1000 × 1200 crossways	Ast	mm	2340
4.34.2	Aisle width for pallets 800 × 1200 lengthways	Ast	mm	2260
4.35	Turning radius	Wa	mm	1500
Performance data				
5.1	Travel speed, laden/ unladen		km/ h	5/5
5.2	Lifting speed, laden/ unladen		m/ s	0.13/0.2
5.3	Lowering speed, laden/ unladen		m/ s	0.13/0.13
5.8	Max. gradeability, laden/unladen		%	8/16
5.10	Service brake type			Electromagnetic
Electric-engine				
6.1	Drive motor rating S2 60 min		kW	1.27
6.2	Lift motor rating at S3 15%		kW	3
6.3	The maximum allowed size battery		mm	330x190x240
6.4	Battery voltage/nominal capacity K20		V/ Ah	2x12/125
6.5	Battery weight		kg	60
Addition data				
8.1	Type of drive unit			AC
10.5	Steering type			Machanical
10.7	Sound pressure level at the driver's ear		dB (A)	74

If there are improvements of technical parameters or configurations, no further notice will be given.  
The diagram shown may contain non-standard configurations.

# Electric Stacker 1.5t

## ES15-33DM

Distinguishing mark	1.1	Manufacturer			EP
	1.2	Model designation			ES15-33DM
	1.3	Drive			Electric
	1.4	Operator type			Pedestrian
	1.5	Load capacity	Q	kg	1500
	1.6	Load center distance	c	mm	600
	1.8	Load distance, centre of drive axle to fork	x	mm	730
	1.9	Wheelbase	y	mm	1165
	Service weight	2.1	Service weight		kg
2.2		Axle loading, laden front/rear		kg	825/1590
2.3		Axle loading, unladen front/rear		kg	560/355
Tyres/chassis	3.1	Tyre type			Polyurethane
	3.2	Tyre size, front		mm	Φ230×75
	3.3	Tyre size, rear		mm	Φ102×73
	3.4	Additional wheels (castor wheels)		mm	Φ100×50
	3.5	Wheels, number front/rear (x=drive wheels)		mm	1x +1/4
	3.6	Tread width, front	b10	mm	538
	3.7	Tread width, rear	b11	mm	1170/1270/1370
Dimensions	4.0	Max. Lift Height	H	mm	—
	4.2	Retracted mast height	h1	mm	2128
	4.3	Free lift	h2	mm	—
	4.4	Lift height	h3	mm	3220
	4.5	Height, mast extended	h4	mm	4210
	4.6	Initial lift	h5	mm	—
	4.9	Height of tiller handle in drive position min./max.	h14	mm	1150/1480
	4.10	Height of wheel arms	h8	mm	101
	4.15	Lowered height	h13	mm	60
	4.19	Overall length	l1	mm	1650
	4.20	Length to face of forks	l2	mm	580
	4.21	Overall width	b1/b2	mm	1270/1370/1470
	4.22	Fork dimensions	s/e/l	mm	40/ 100/ 1070
	4.24	Fork carriage width	b3	mm	800
	4.25	Distance between fork-arms	b5	mm	200~780
	4.26	Distance between wheel arms/loading surfaces	b4	mm	1070/1170/1270
	Performance data	4.31	Ground clearance, laden, below mast	m1	mm
4.32		Ground clearance, center of wheelbase	m2	mm	30
4.34.1		Aisle width for pallets 1000×1200 crossways	Ast	mm	2250
4.34.2		Aisle width for pallets 800×1200 crossways	Ast	mm	2200
4.35		Turning radius	Wa	mm	1400
5.1		Travel speed, laden/unladen		km/h	5/5
5.2		Lifting speed, laden/unladen		m/s	0.14/0.2
5.3		Lowering speed, laden/unladen		m/s	0.13/0.11
5.8		Max. gradeability, laden/unladen		%	8/16
5.10		Service brake			Electromagnetic
Electric-engine	6.1	Drive motor rating S2 60 min		kW	1.27
	6.2	Lift motor rating at S3 15%		kW	3
	6.4	Battery voltage/nominal capacity		V/Ah	24/125
	6.5	Battery weight		kg	60
Addition data	8.1	Type of drive control			AC
	10.5	Steering design			Mechanical
	10.7	Sound pressure level at the driver's ear		dB(A)	74

If there are improvements of technical parameters or configurations, no further notice will be given.  
The diagram shown may contain non-standard configurations.

# ES15-15ES

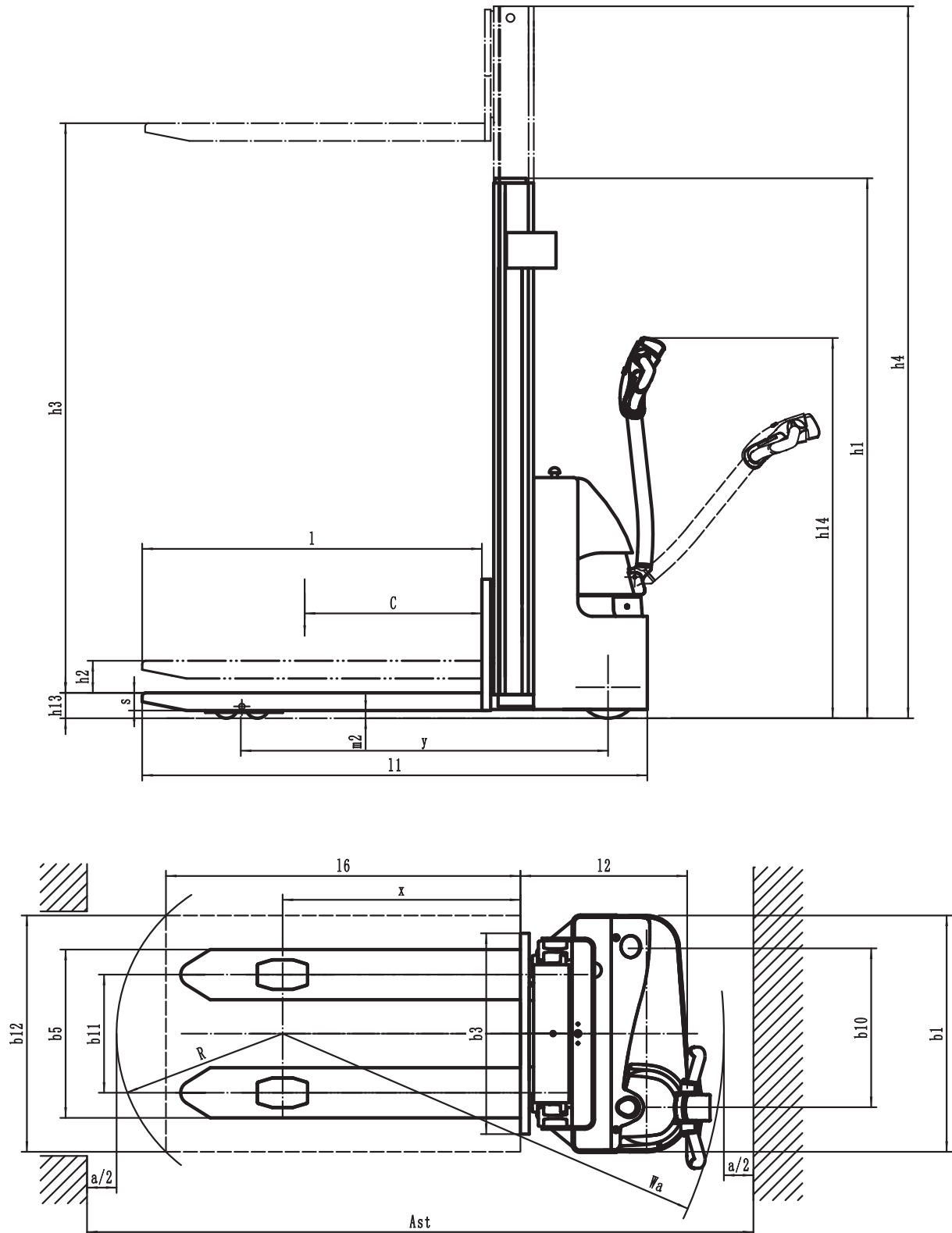

# ES15-33DM

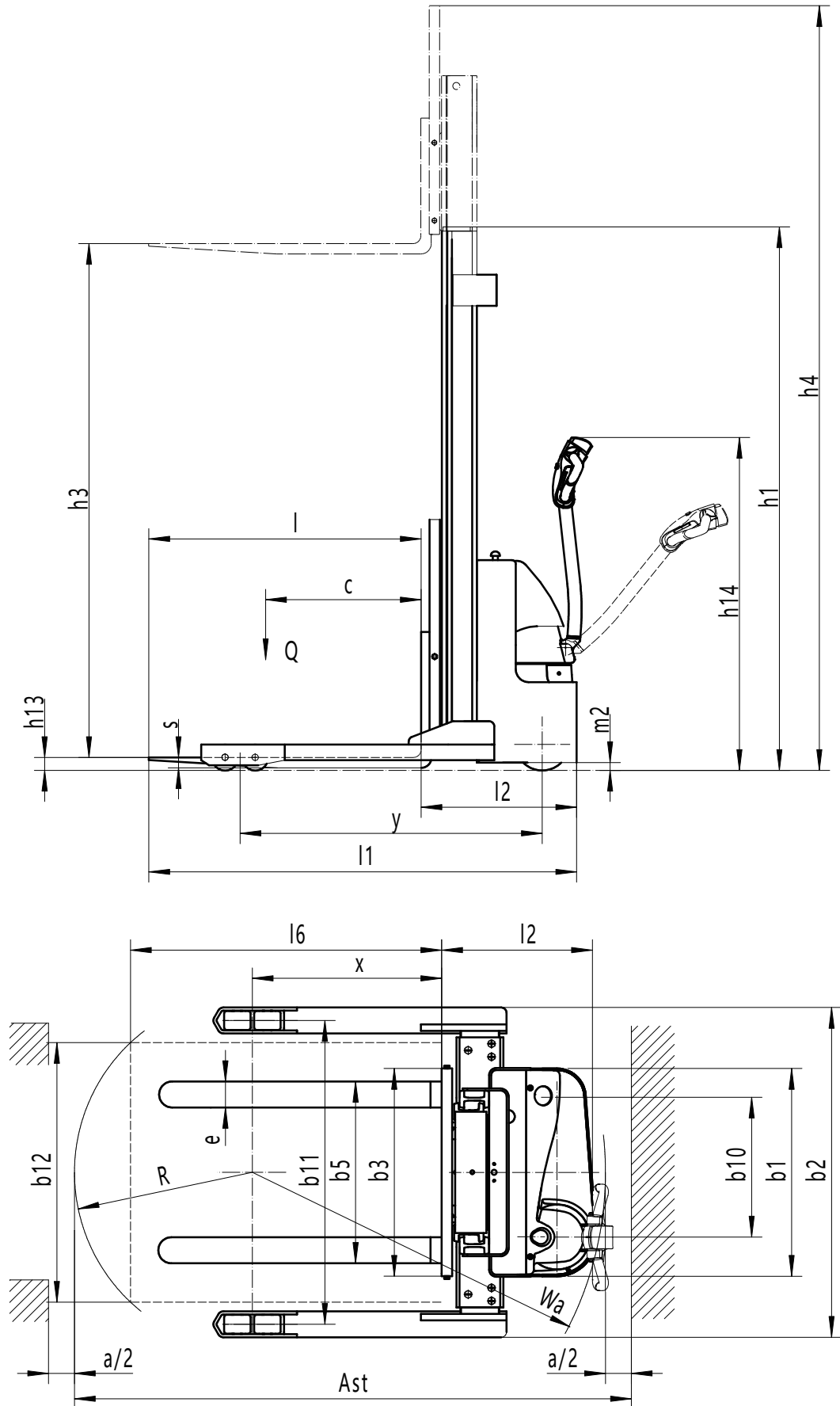

ES15-15ES  
RATED CAPACITIES GRAPH



ES15-33DM  
RATED CAPACITIES GRAPH

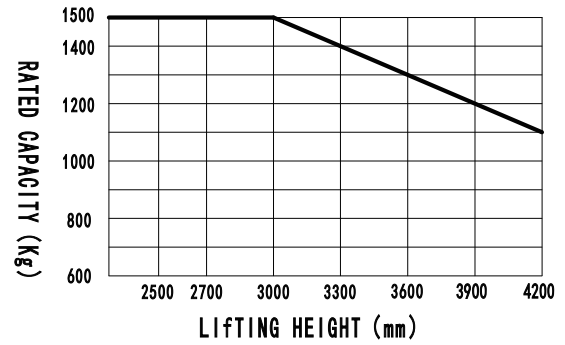

## Mast Option

### ES15-15ES

Mast types	Lift height h3+h13(mm)	Height, mast lowered h1(mm)	Free lift h2(mm)	Height, mast extended h4(mm)
2-Standard Mast	2515	1728	—	2943
	2715	1828	—	3143
	3015	1978	—	3443
	3315	2128	—	3743
	3615	2278	—	4043
	4015	2478	—	4443
	4165	2553	—	4593

### ES15-33DM

Mast types	Lift height h3+h13(mm)	Height, mast lowered h1(mm)	Free lift h2(mm)	Height, mast extended h4(mm)
2-Standard Mast	2490	1728	—	3410
	2690	1828	—	3610
	2990	1978	—	3910
	3290	2128	—	4210
	3590	2278	—	4510
	3990	2478	—	4710
	4140	2553	—	4860

## Option

No.	Optional items	ES15-15ES
1.1	Fork dimension	●570*1150 ○570*1000、1220 ○685*1000、1150、1220
1.4	Fork carriage width	●680mm○780mm
2.1	Load wheel type	●Double
2.2	Load wheel material	●PU
2.3	Drive wheel material	●PU
2.7	Battery capacity	●125Ah
2.8	Charger	●24V-15A Internal
2.9	Battery indicator	●With time
2.16	handle head type	●Hands big handle head
3.3	Castor wheels	●Yes and not customized
3.16	Vertical handler working	●No○Yes and not customized
Note: ●Standard ○ Optional - Inconformity		

## Option

No.	Optional items	ES15-33DM
1.1	Fork dimension	●900*600、2A、100*40*1070○900*600、2A、100*40*1150 ○900*600、2A、100*40*1220○900*600、2A、100*40*1370
1.2	Leg width	●1070○1170/1270
1.4	Fork carriage width	●800mm(31.5in)
1.5	backrest height	●916mm (36in)
2.1	Load wheel type	●Double
2.2	Load wheel material	●PU
2.3	Drive wheel material	●PU○Trace PU
2.7	Battery capacity	●125Ah○100Ah
2.8	Charger	●24V-15A Internal
2.9	Battery indicator	●With time
2.16	handle head type	●Hands big handle head
3.3	Castor wheels	●Yes and not customized
3.16	Vertical handler working	●No○Yes and not customized
Note: ●Standard ○ Optional - Inconformity		